

# 6.26 FULL ELECTRIC

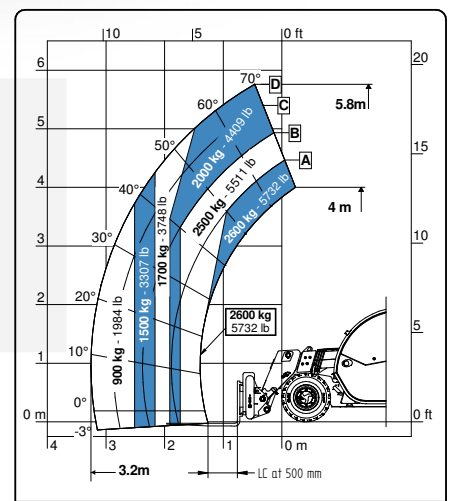

It brings to the attention of all potential customers, all recipients, and to the maximum extent possible, external interlocutors, that Faresin Industries S.p.A. adopts a general Disclaimer regarding the description of the technical and functional characteristics of its machineries, as well as the manner of their use, also with regard to their safety. The Disclaimer must be understood as having a general scope, and therefore Faresin Industries s.p.a. invites to know it, also by accessing the website: [www.faresindustries.com](http://www.faresindustries.com)

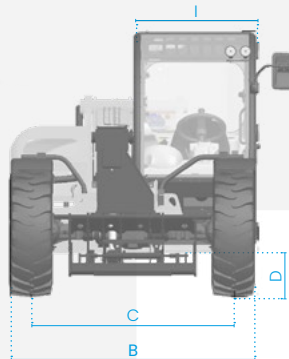
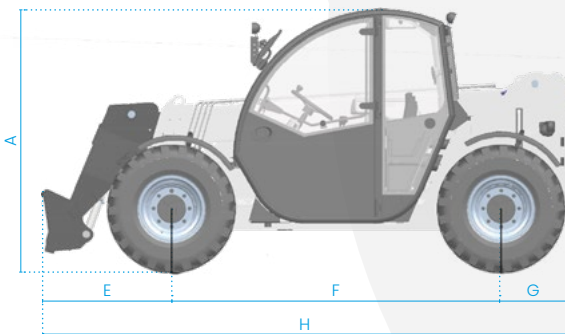

**FARESIN.COM**



# 6.26 FULL ELECTRIC

## TECHNICAL FEATURES



MODELS		6.26E
<b>DIMENSIONS</b>		
Height	ft	6.3
Width	ft	6.2
Length	ft	13.2
Cabin width	ft	3.1
<b>WEIGHT</b>		
Weight	lbs	10,582
<b>DETAILS</b>		
Number of extracting sections	nr	1
Max capacity	lbs	5,732
Max lifting height	ft	19.4
Max horizontal boom extension	ft	10.5
Boom extension at max height	ft	1
Swinging Angle	°	155
<b>TANK CAPACITY</b>		
Hydraulic oil tank	gal	18.5
<b>CONNECTION FOR EQUIPMENT</b>		
FH		●
EURO		○
<b>TYRES</b>		
12-16,5		●
Turning radius	ft	10.6

NOTE: All dimensions defined on model with wheels 12-16,5

● Standard ○ Optional - Not available

CONFIGURATIONS		FULL ELECTRIC
<b>TRANSMISSION</b>		
Transmission		electric
Speed	mph	7.5
<b>MOTOR</b>		
Transmission S2	kW	30
Hydraulic services S3	kW	18
<b>HYDRAULIC</b>		
Pump type		gears pump
Hydraulic capacity	gal/psi	21.1/3,335
<b>OTHER</b>		
Joystick		mechanical-electro proportional
Cabin		Queen Cab
Quick coupling		○
Front and rear LED lights		○
Floating boom		○
Boom suspension		○
Manual 6-way diverter		○
PEB (Boom Electric Socket)		○
Front constant flow		○
Bucket mode		●
<b>SPECIAL FEATURES</b>		
Air conditioning		○
Forward buzzer avas		○
Farmatics		FULL (2-5 years)

POWER AND BATTERY CAPACITY	24 kW/h (315 Ah)	32 kW/h (420 Ah)	43 kW/h (560 Ah)
AUTONOMY STANDARD CYCLE INTENSIVE (eco mode)	UP TO 3 HOURS	UP TO 4 HOURS	UP TO 6 HOURS
AUTONOMY STANDARD CYCLE NOT INTENSIVE (eco mode)	UP TO 6 HOURS	UP TO 8 HOURS	UP TO 11 HOURS

CHARGERS				
<b>STANDARD ON BOARD MONO PHASE CHARGER</b>	0-80%	10 h	13 h	/
	POWER INPUT 16 A POWER OUTPUT 16 A (effective) 80 VDC	0-100%	13 h	16 h
<b>EXTERNAL THREE PHASES CHARGER 480V - 80A</b>	0-80%	3 h 10 m	4 h 30 m	5 h 40 m
	POWER INPUT 18 A POWER OUTPUT 80 A (effective) 80 VDC	0-100%	4 h 50 m	6 h 20 m
<b>EXTERNAL THREE PHASES FAST CHARGER 575V - 200A</b>	0-80%	2 h 20 m	3 h	3 h 50 m
	POWER INPUT 43 A POWER OUTPUT 200 A (effective) 80 VDC	0-100%	3 h 30 m	4 h 30 m
<b>EXTERNAL THREE PHASES FAST CHARGER 400V - 200A</b>	0-80%	1 h 10 m	1 h 40 m	2 h 10 m
	POWER INPUT 43 A POWER OUTPUT 200 A (effective) 80 VDC	0-100%	2 h	2 h 45 m